



Gantry Anticollision System for Quay Cranes

Control Unit
Installed in Crane E-
House allows for
complete control of
system



Laser Installed on
Quay Crane

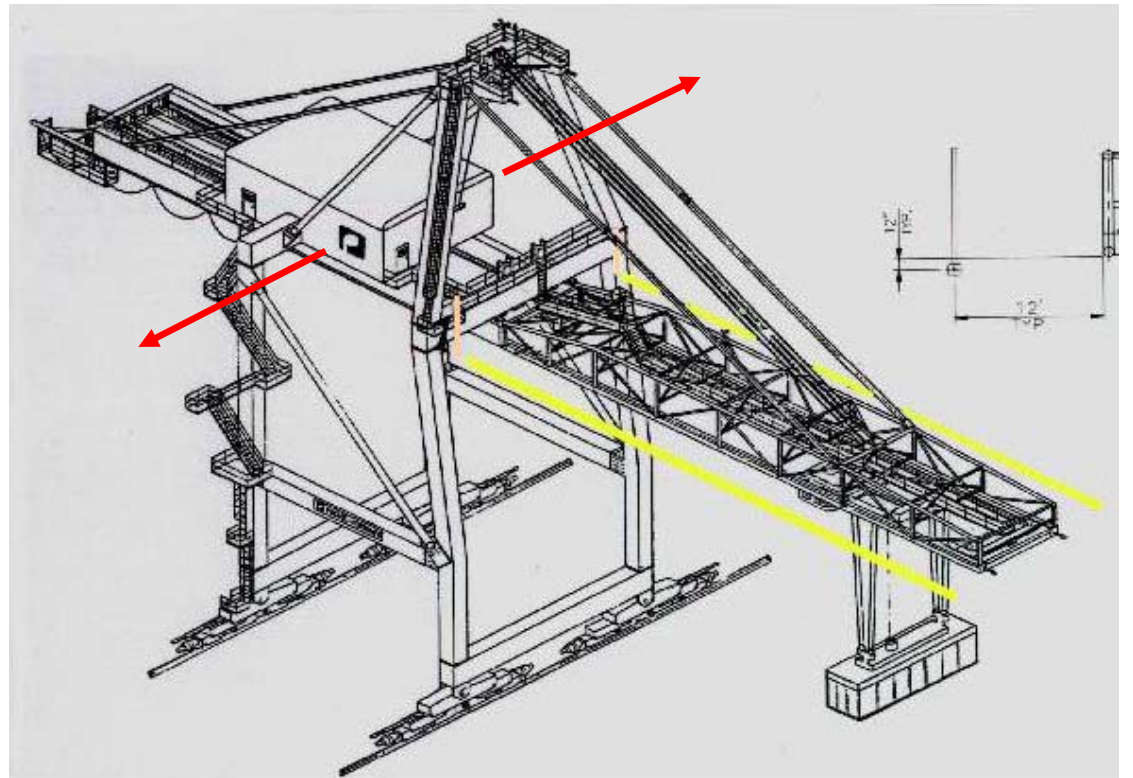

PACECO® CORP. Boom Anticollision Laser Trajectory Protection Area (Arrows in Red)

This system is designed to protect adjacent cranes from colliding with one another and causing damage to a crane or neighboring object. Lasers are mounted such that the beams trajectory as shown by the arrows in red in the figure above. If the crane gets too close to a preprogrammed distance (i.e. a neighboring crane working adjacent to the gantrying crane), the control unit will shutdown the crane gantry drive to prevent damage to the crane.

This added protection can prevent costly damage to the crane while also maintaining safety when more than one crane is working. This is extremely important for busy ports that may have multiple cranes working in close proximity to one another while moving containers on and off of a vessel.

Features & Benefits

- Maintains crane uptime and protects against costly repairs.
- Often will reduce insurance premiums for a terminal.
- Programmable Logic Controller (PLC) based control unit with dry contact on-off signaling in the event of a fault installed in the crane e-house
- Programmable distance can be set to signal a shutdown signal to the gantry drive (from 2 feet to 200 feet).
- System can be shutdown via the main control unit in the crane e-house or remotely.
- Disable modes (such as when the boom is boomed up)
- Buzzer warning signals can be made available in the operator cab.
- Shutdown signals available to the crane drive system and in the operator cab.
- All weather enclosure can be mounted inside or outside.

For more information about this or other PACECO® CORP. products please contact us at (510) 264-9288

THE PACECO® CORP. ADVANTAGE

Extensive Experience with Quay Crane and RTG Manufacturing and Design • Experts in large scale deployments of custom hardware and software technology for harsh environments • In house software and hardware group for quick turn of software and hardware design and support • Local Inventory of Technology Hardware stored on-site at corporate headquarters in Hayward, CA • PACECO CORP. stands behind its products. We service what we sell • All products sold have on-call and on-site support and hardware replacement programs available • Extended Service maintains backward compatibility to end of life products.